

Designing a Root Zone Heating System

John W. Bartok, Jr.
Extension Agricultural Engineer

Optimum root temperature reduces the time to root cuttings and germinate seed. Also, research has shown that root zone temperature is more critical than leaf temperature in achieving good plant growth.

If the root zone temperature is maintained at the optimum, the air temperature in the greenhouse can be lowered as much as 15°F. This reduces heat loss from the greenhouse and, thereby, energy consumption. Poinsettia, cineraria, calceolaria, dieffenbachia, roses and bedding plants will do well with a cooler night air temperature.

System Components

A typical system contains piping, circulating pump, water heater or boiler and control system. To be effective, the system must be designed to provide uniform temperature over the floor or bench area.

The system operates by circulating hot water (from 90° to 110°F) through pipe loops connected to supply headers. By having the loops the same length and using a reverse return supply system, temperature will be the same anywhere in the heated area.

Piping

The least expensive pipe is polyethylene which comes in 100' and 400' rolls. It will take water temperatures up to 130°F. Nylon fittings and stainless steel clamps will minimize the potential for leaks. Fittings that are buried belowground should have double clamps.

Semirigid Polyvinyl chloride (PVC) can also be used. It is available in 10' and 20' lengths and will take water temperatures to 140°F. Fittings are connected with pipe cement.

Polybutylene pipe has been successfully used in many root zone heating systems. It is flexible and can withstand temperatures below freezing and above 500°F. Fittings can be attached with clamps or joints can be made on site by heat fusion.

Most commercially available systems use EPDM rubber tubing either as single tubes or as two or four tubes attached by a web. The 1/4" diameter tubing is connected to plastic or copper headers with plastic inserts or brass fittings. Some manufacturers offer custom-made, ready-to-install modules with headers to fit your bench width and length. This preassembled unit is pressure tested at the factory. Installation is easy and requires only two plumbing connections to the supply and return lines.

In all installations, copper or galvanized pipe should be used for the first 10' from the heater or boiler. This protects the plastic pipe from the high temperature at this point.

System Layout

PVC pipe is the most common material for the supply piping to bring the water from the heater or boiler to the growing area. A reverse return (three-pipe) system is used so that the water to all the loops travels the same distance. The layout is shown in **Figure 1**. Recommendations for sizing are given in **Figure 2**. On long runs and in unheated areas, supply and return pipes should be insulated to save energy.

For EPDM rubber installations, follow the manufacturer's recommendations for spacing, length of run and circulating pump size. The tubing can be buried in sand on the floor or placed on top or underneath the bench.

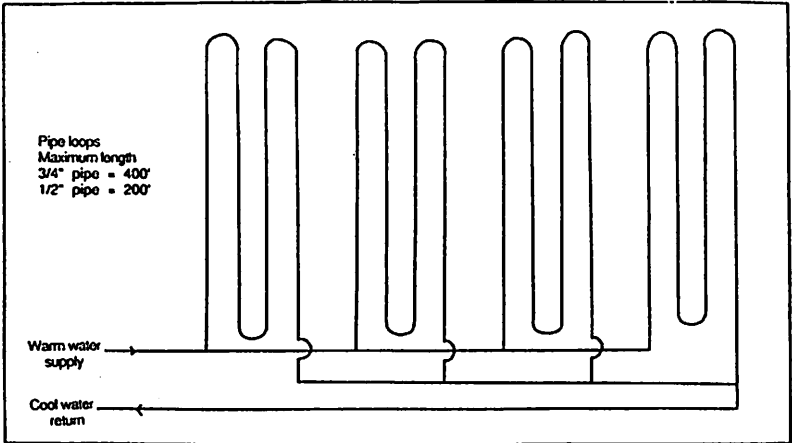

Figure 1. Typical pipe layout for floor or bench heating (reverse return).

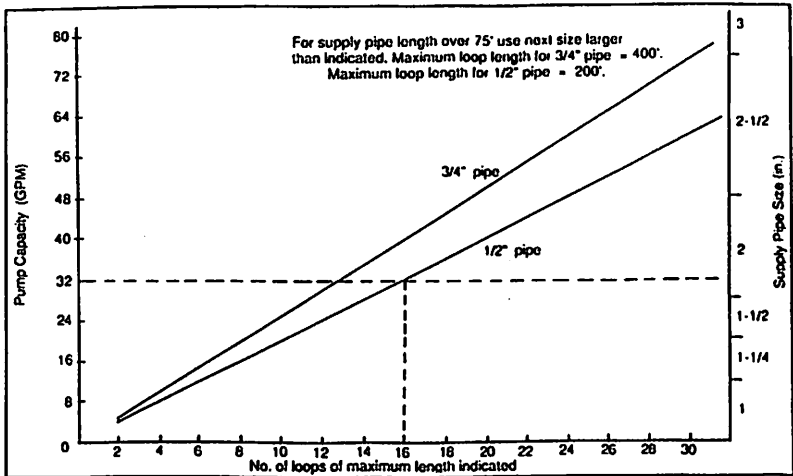

Figure 2. Pump capacity and supply header size for PE pipe bottom heat.

Some manufacturers supply a slotted insulation board for placing the tubing on top of the bench.

For floor installations, space the pipes 12" to 15" apart and 8" to 12" deep in the soil. For tomatoes or cucumbers grown in bags or troughs, one line of pipe under each row has been found to work well.

For benches, a 6" to 9" spacing covered by 3" to 4" of sand will provide even temperature. The sand should be kept wet to transfer the heat and is usually covered with a sheet of plastic. An alternative arrangement consists of laying the pipe in the bottom of the bench and covering with wire mesh and a layer of plastic. Some growers have attached the pipe underneath the bench to get it out of the way and to allow the heat to spread.

Heat loss from plastic and rubber material is relatively slow, so lengths up to 400' for 3/4" pipe and 200' for 1/2" pipe do not result in a very wide temperature differential between the supply end of the loop and the discharge. All loops should be the same length so that flow through each loop travels the same distance.

Heater Size

The size of the loops should be made as large as practical so that the header and pump size can remain small. Stay within the 400' and 200' recommendations given above. To keep an even flow of water within the pipes and eliminate air pockets, a flow rate of 2 and 2.5 gallons per minute (gpm) is used for the 1/2" and 3/4" pipe, respectively. **Figure 2** can be used to determine pump capacity required.

Select a pump that has a pressure head of 10 to 15 pounds per square inch (psi). Pumps used in hot water heating systems and solar systems work well. They are available from heating supply houses and greenhouse suppliers.

The size of the water heater boiler needed depends on the amount of area to be heated and the cropping system used. Research at Rutgers University by Roberts and Mears indicated a heat loss of approximately 20 Btu/sq. ft.-hr. for beds or benches with plants growing in the soil and 15 Btu/sq. ft.-hr. for beds or benches covered with flats. This was based on a water temperature of 100°F. entering the loops. Some manufacturers of rubber tubing

recommend water temperature as high as 140°F. which will increase heat loss. Temperatures over 110°F. can cause root damage on some crops.

The amount of heat needed can be calculated by multiplying the square feet of bench or bed area by the heat loss from the area. For example it will require a water heater with a capacity of 60,000 Btu/hr. to heat 3,000 sq. ft. of bench area covered with pots (3,000 sq. ft. x 20 Btu/sq. ft.-hr. = 60,000 Btu/hr.). (See **Figure 3**.)

For greenhouses up to about 3,000 sq. ft., a household water heater fired by natural gas, propane or electricity has worked well. Instantaneous water heaters that are placed in line have also been used by some growers. Both types of heaters are available in several sizes. **Figure 4** shows a typical plumbing arrangement. The thermostat on the heater can either be set to 100°F. to maintain water temperature or it can be set to 180°F. and a mixing valve used to temper the water before it enters the loops.

In larger greenhouses, a hot water boiler should be used. Generally it is sized to provide the total heat needs, both root zone and air heat. The system can be zoned with a circulating pump and sensor for each. Boiler water

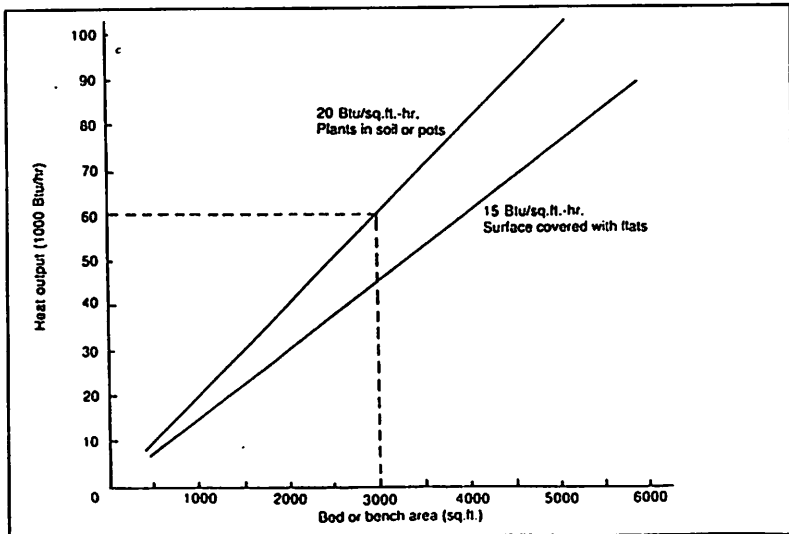

Figure 3. Heat flow from bottom heat in floors or benches.

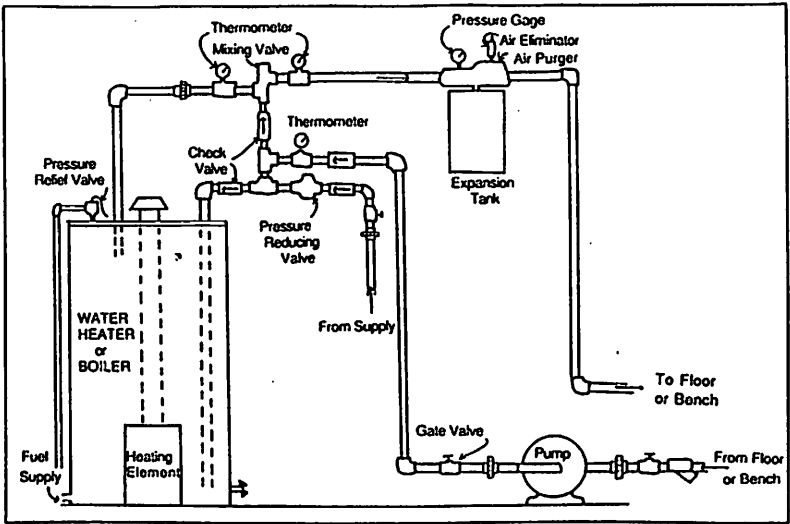

Figure 4. Piping schematic for bottom heat system.

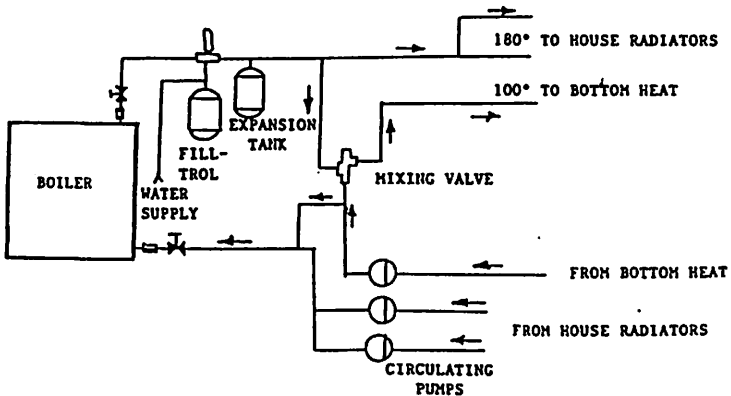

Figure 5. Connecting bottom heat to a home heating boiler.

temperature is usually set at 180°F. during the winter to provide the air heat through unit heat exchangers or fin radiators. A mixing valve is installed in the piping system to lower the water temperature to 100°F. for the root zone heat. Refer to **Figure 5**.

All closed loop systems require the use of a prepressuring, diaphragm-type expansion tank, an air eliminator and vent installed on the supply pipes as close to the hot water source as possible. This handles the expansion of the water when it is heated and eliminates any air in the system that could affect the flow of water.

Control

Sensors for the root zone heat should be of the remote bulb type and located in the soil bed or flat in a representative location. Controls should be set so that the root zone is the first stage of heat, as this is the most important and also provides the greatest energy efficiency.

The cost of installing a root zone heating system will vary depending on the type of heater and piping used. For a typical 25' x 96' hoophouse with movable benches and a propane gas hot water heater, materials will cost about \$2,000 for a poly pipe system and \$4,000 for an EPDM rubber tubing system.

The use of root zone heating has proven to be an effective way to get better propagation of seeds and cuttings. Growers also find that the quality of plants is improved. Energy savings due to lower air temperature can be as much as 10%.

