

STABY - OSU

QUALITY SORTING
OF
RED DELICIOUS APPLES
BY LIGHT TRANSMISSION

Marketing Research Report No. 936

Agricultural Research Service

UNITED STATES DEPARTMENT OF AGRICULTURE

Aulenbach '72

Aulenbach '72

ACKNOWLEDGMENTS

The writers acknowledge the assistance of Karl H. Norris for instrumentation advice, David R. Massie for help with data analyses, and staff members of the Market Quality Research Division for cooperative service as taste panelists.

Contents

	Page
Summary	1
Introduction	1
Materials and methods	2
1965 exploratory work	2
1966 test	5
1967 test	5
Results and discussion	5
1965 exploratory work	6
1966 test	13
1967 test	20
Conclusions and recommendations	20
Literature cited	21

Trade names are used in this publication solely for the purpose of providing specific information. Mention of a trade name does not constitute a guarantee or warranty of the product by the U.S. Department of Agriculture or an endorsement by the Department over other products not mentioned.

Washington, D.C.

Issued May 1972

For sale by the Superintendent of Documents, U.S. Government Printing Office,
Washington, D.C. 20402—Price 20 cents

Stock Number 0100-1521

QUALITY SORTING OF RED DELICIOUS APPLES BY LIGHT TRANSMISSION

By

BARBARA B. AULENBACH, JOHN N. YEATMAN, and JOHN T. WORTHINGTON
Market Quality Research Division, Agricultural Research Service

SUMMARY

In a 3-year test, $\Delta OD(700-740 \text{ nm.})$ (the optical density difference between 700 nm. and 740 nm.) was a more reliable indicator of quality in Red Delicious apples than $\Delta OD(580-640 \text{ nm.})$. Apples with low $\Delta OD(700-740 \text{ nm.})$ values (low-chlorophyll content) compared with those in the high range were generally sweeter, less tart, more flavorful, and higher in overall quality. The relationship between $\Delta OD(700-740 \text{ nm.})$ value and firmness varied from year to year.

For Red Delicious apples harvested either over an extended (30-day) period or a more nearly typical commercial (9-day) period $\Delta OD(700-740 \text{ nm.})$ value at harvest was related to eating quality after as long as 6 months' storage at 32° F.

The proportion of apples in each $\Delta OD(700-740 \text{ nm.})$ category shifted during a 30-day harvest period. More apples in the low-chlorophyll (high-quality) category were found in the later harvests.

INTRODUCTION

Light transmission is an established nondestructive technique for evaluating the internal quality of many horticultural products. Although an apple transmits less than 0.1 percent of the light falling on it, the characteristics of this transmitted light have been related to quality and maturity (2).¹

Norris (5) described an instrument for measuring spectral transmittance curves of intact agricultural products. He illustrated the possible use of these curves to indicate maturity, internal color, and internal defects. Less mature Jonathan apples were distinguished from more mature Jonathans by higher absorption in the chlorophyll region (675 nm.) and lower absorption in the region around 550 nm.

The difference meter, developed by Birth and Norris (2), measures the optical density (OD)

of a sample at two wavelengths chosen from complete spectral curves and computes the difference, $\Delta OD(\lambda_1-\lambda_2)$. A measuring wavelength related to the desired characteristic and a reference wavelength must be carefully selected to successfully evaluate internal quality.

Sidwell and others (7) found that $\Delta OD(700-740 \text{ nm.})$ correlated +0.957 with log chlorophyll content of Elberta peaches. They concluded that light transmission appeared promising for peaches as an indicator of chlorophyll content and stage of maturation.

Yeatman and Norris (8) sorted apples for eating quality with an automatic internal quality (IQ) sorter. They reported a correlation coefficient of -0.957 between log chlorophyll content of apples and $\Delta OD(740-695 \text{ nm.})$. Taste panelists preferred apples in the low-chlorophyll category, even after 6 months' storage at 32° F. Eastern-grown Stayman, Winesap, and Golden Delicious were the varieties sorted successfully.

¹ Italic numbers in parentheses refer to Literature Cited, p. 21.

Testing the same IQ sorter in the Pacific Northwest, Olsen and others (6) sorted Golden Delicious apples by internal chlorophyll, as measured by $\Delta OD(690-740 \text{ nm.})$. The taste panelists gave apples in the low-chlorophyll category the highest ratings for dessert quality. Apples in the high-chlorophyll category represented three harvests and varied in acid content. The authors (6) concluded that categories of Golden Delicious apples obtained with the IQ

sorter are more closely associated with quality than with maturity.

The objectives of this research were to (1) search for wavelength pairs that might be more closely related to apple quality than $\Delta OD(695-740 \text{ nm.})$, (2) evaluate light transmission as a quality-sorting technique for Red Delicious apples, and (3) compare controlled atmosphere (CA) and conventionally stored apples that had been previously sorted by light transmission.

MATERIALS AND METHODS

1965 Exploratory Work

Spectral curves of intact Red Delicious apples were obtained at 10 nm. intervals from 380 to 740 nm. with a multipurpose spectrophotometer in the Beltsville Instrumentation Research Laboratory, Beltsville, Md. Red Delicious apples from two harvests, about 1 week apart, were included for each of the following strains: Standard Red and an unidentified red bud sport from Howard County, Md., and Starking from Washington State. Eighty apples per harvest of each strain were measured.

The optical density at 650 nm. and the following optical density differences (ΔOD) were taken from the punched-tape record of the spectral curve for each apple: 580-630, 580-640, 590-640, 600-640, 630-660, 630-720, 680-730, 680-740, and 700-740 nm. These apples were then stored in conventional storage at 32° F. for 4 months. At the end of this storage period, six experienced taste panelists rated general eating quality and sweetness on peeled wedges from each apple. These panelists used a 10-point rating scale (2 - very poor, 9 - very good; 2 - very sour, 9 - very sweet). Red lights in the taste panel booths masked differences in apple flesh color. Average taste panel scores for each apple were correlated with each of the values taken from its spectral curve to select a light-transmission measurement that was most closely related to apple quality.

1966 Test

Red Delicious (Red King) apples were harvested weekly for 4 weeks (September 15-

October 19) from an orchard near Mercersburg, Pa. On each harvest date, 10 bushels were picked from three trees selected at random from a block of mature trees. After mechanical sizing, apples 3 to 3¼ inches in diameter were selected for light-transmission sorting.

A 4-filter model of the difference meter (2) was used for all light-transmission measurements. In this abridged spectrophotometer, four interference filters are arranged in a wheel, and any two optical density differences can be read simultaneously on two meters. On each meter, the 100-unit scale can be divided into sections of any desired width, representing categories. Categories based on a range values are more practical than exact numerical values (fig. 1).

Fifty apples, selected at random from each harvest, were checked for water core, using $\Delta OD(760-815 \text{ nm.})$ (3). Water core can increase experimental error by causing apples to be incorrectly sorted. Water-cored apples appear to the difference meter to be more mature than they really are at harvest because the translucent tissue transmits more light. Internal browning in stored water-cored apples causes them to appear to the difference meter to be less mature. Since no water core was found in the sample, a presorting of all apples was not necessary.

In the sorting room the temperature was maintained at 45° F. because large temperature fluctuations can cause variable difference meter readings. One fluorescent tube provided light in the sorting area. It was filtered with green cellophane to minimize visible light that would cause chlorophyll in apples to fluoresce. If this

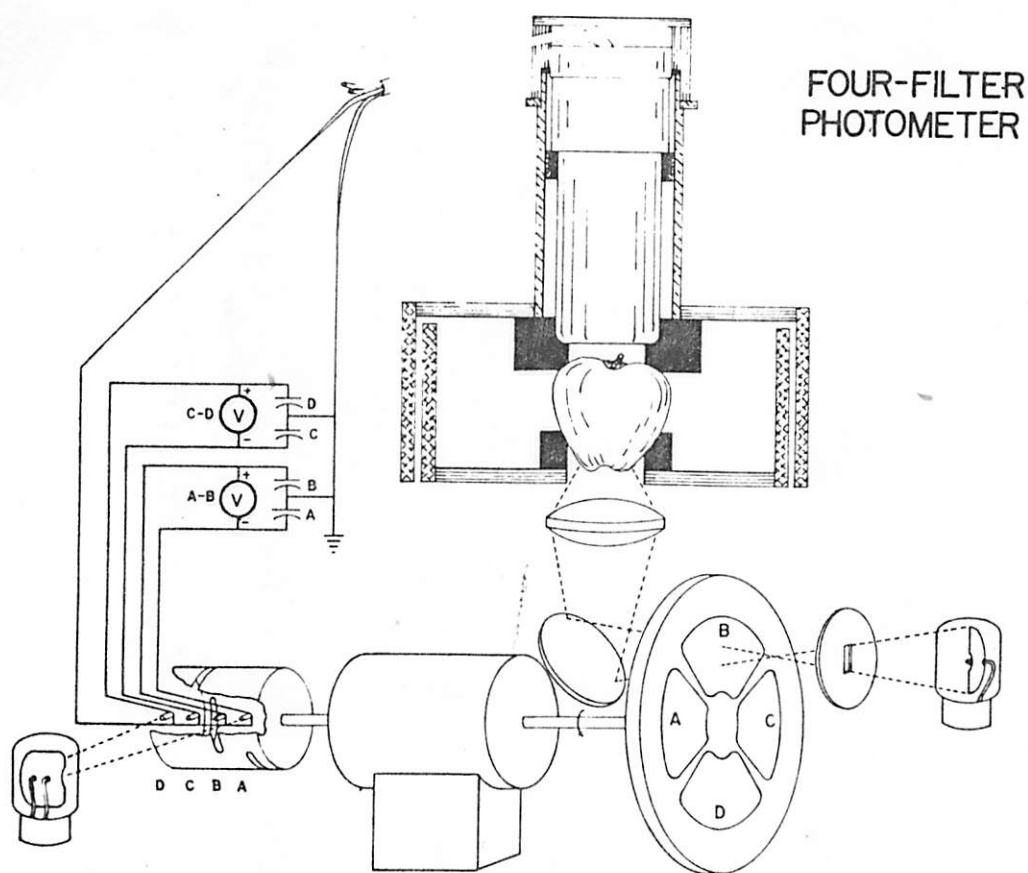

FIGURE 1.—Schematic of 4-filter difference meter.

precaution were not taken, fluorescing apples would cause errors in light transmission instrument readings.

Difference meter settings for quality sorting were 0.5 OD full scale span for ΔOD (580–640 nm.) and 1.0 OD full scale span for ΔOD (700–740 nm.). A preliminary sort showed that the range of test apples could be sorted into five categories by ΔOD (580–640 nm.) and into four categories by ΔOD (700–740 nm.). Each category represented 20 units on a 100-unit scale.

Twenty bushels of apples were sorted by each wavelength pair, keeping the four harvests separate. The weights of apples sorted into each category were recorded according to harvest, and percentage distributions by weight were calculated for each category. The relationship between harvest date and category may be use-

ful in predicting the best time to harvest for high-quality apples.

One hundred apples per category were needed for the following experimental plan: 10-apple composite samples tested for 5 consecutive days, at harvest and after commercial CA storage (3 percent oxygen (O_2), 2–3 percent carbon dioxide (CO_2), 32° F.). To obtain 100 apples per category, apples from all four harvests had to be combined in the composite samples. The percentage distributions calculated during sorting were used to make up 10-apple samples representative of all apples sorted. By using this method instead of choosing apples randomly from the four harvests, the five composite samples for any category were as similar as possible. The procedure is illustrated by the following example for ΔOD (580–640 nm.):

Harvest	Percentage (by weight) in category 1	Number of apples in sample
1	24	2
2	59	6
3	12	1
4	5	1
Total, category 1	100	10

Laboratory and taste panel tests were conducted in October 1966 and April 1967. To eliminate any time-of-day effect, categories of one wavelength pair were evaluated in the morning and those of the other pair in the afternoon, alternating these assignments over the 5 days. Optical density differences were measured after storage to note any changes.

Laboratory Tests and Taste Panel Procedures

Firmness was measured with a Magness-Taylor pressure tester (3- to 30-lb. scale), using a $\frac{3}{16}$ -inch diameter probe with a penetration of $\frac{5}{16}$ inch. Two pared areas on opposite sides of each apple were tested. Apples were then peeled, cored, cut into wedges, and cubed with

a french-fry cutter. Cubes from the 10 apples in a sample were thoroughly mixed to form a composite. Soluble solids were read on an Abbe refractometer, using juice squeezed from 150 grams of apple cubes in a Carver press. Fifty milliliters of juice was titrated with 0.1N NaOH to pH 7.0, and acidity was calculated as malic acid.

Apple tissue (150 grams per sample) was freeze dried before chlorophyll extraction with 85-percent acetone. The chlorophyll was transferred from the acetone phase to anhydrous ethyl ether by repeated extraction in a separatory funnel. Spectral curves of the ether extract were obtained with a Bausch and Lomb 505 recording spectrophotometer, and chlorophyll content was calculated as micrograms per gram of dry weight. The extraction and calculation procedure was adapted from a modified Association of Official Agricultural Chemists method (8).

Five experienced judges scored portions of each composite sample for texture, juiciness, sweetness, tartness, apple flavor, and overall reaction, using the rating scale in figure 2. At

TEXTURE	JUICINESS	SWEETNESS	SCORE	TARTNESS	FLAVOR	OVERALL REACTION
TOUGH	VERY JUICY	VERY SWEET	7-7	VERY TART		LIKE VERY MUCH
---	---	---	6-6	---		LIKE MODERATELY
CRISP	SLIGHTLY JUICY	MODERATELY SWEET	5-5	MODERATELY TART	FULL FLAVORED	LIKE SLIGHTLY
---	---	---	4-4	---	---	NEITHER LIKE NOR DISLIKE
SLIGHTLY MEALY	SLIGHTLY DRY	SLIGHTLY SWEET	3-3	SLIGHTLY TART	WEAKLY FLAVORED	DISLIKE SLIGHTLY
---	---	---	2-2	---	---	DISLIKE MODERATELY
VERY MEALY	VERY DRY	NEUTRAL	1-1	NEUTRAL	FLAT	DISLIKE VERY MUCH

FIGURE 2.—Apple quality rating scales, 1966 and 1967.

each sitting, judges tasted four or five samples, randomly presented one at a time, in separate booths under red masking light.

1967 Test

In the 1967 tests, the comparison of two wavelength pairs, $\Delta OD(580-640 \text{ nm.})$ with $\Delta OD(700-740 \text{ nm.})$, as measurements of apple quality was continued. Standard Red Delicious apples, harvested over a 9-day period, were purchased from a packinghouse in Charles Town, W. Va. The apples ($3\frac{1}{8}$ -inch diameter) were a mixture of West Virginia Extra Fancy, U.S. Fancy, and U.S. No. 1 grades.

The experimental plan included two types of 32° F. storage at Beltsville (CA and conventional), four test dates (at harvest and at 2, 4, and 6 months' storage), and two replications (days) per date, using composite samples of 10 apples. About 2,000 apples were sorted by each of the two wavelength pairs.

A preliminary sort with the difference meter showed that the 0.5 OD full scale span used for $\Delta OD(580-640 \text{ nm.})$ in 1966 needed no adjustment. For $\Delta OD(700-740 \text{ nm.})$, the full scale span was changed from 1.0 to 0.5 OD to obtain more than one category. Because 1966 results indicated that three categories would sort as effectively as four or five, apples were sorted into three categories by each wavelength pair. Each category represented 25 to 30 units on a 100-unit scale. Conditions in the sorting room were the same as in 1966.

For the actual tests, 200 apples were selected at random from the apples in each category,

100 for each storage. Difference meter readings for both wavelength pairs were recorded for each apple to study the relationship between $\Delta OD(580-640 \text{ nm.})$ and $\Delta OD(700-740 \text{ nm.})$. Laboratory and taste panel tests were conducted in October and December 1967 and in February and April 1968. At the start of each 2-day test, 20 apples were chosen at random from each category in the two storage rooms. Difference meter readings for the two optical density differences were recorded for comparison with readings at harvest. Laboratory procedures were the same as those used in 1966, except that chlorophyll was extracted only from apples sorted by $\Delta OD(580-640 \text{ nm.})$. Taste panel procedures were also the same, except that judges tasted six samples per sitting.

The atmosphere in the CA room was modified by an Arcogen unit with an Arcat oxygen burner. Because this room could not be tightly sealed, the average oxygen level was 6 percent, higher than the 1 to 3 percent found to be best for Red Delicious CA storage (1). The carbon dioxide level in the CA room averaged 2 percent, and the relative humidity in both storage rooms was 85 to 90 percent. The Arcogen unit was shut down for about 8 hours when the 2- and 4-month samples were removed. Although the atmosphere in the CA room was modified, it varied considerably from recommended conditions. This CA room was part of an experimental system undergoing its first tests.

Unless otherwise noted, all differences discussed in Results and Discussion for 1966 and 1967 are statistically significant at the 5-percent level.

RESULTS AND DISCUSSION

1965 Exploratory Work

Taste panel scores for general eating quality correlated poorly with all light transmission measurements (average $r = + 0.150$). Correlation coefficients for sweetness judgments versus optical density differences were consistently higher than those for general eating quality. In scoring sweetness, panelists could concentrate on one quality factor and variability among panelists was lower.

Correlations of sweetness versus optical density differences were highest for the second harvest of the Standard Red apples, the strain that also covered the widest quality range. For these apples, $\Delta OD(580-640 \text{ nm.})$ was the wavelength pair most closely related to sweetness scores ($r = + 0.741$). This correlation coefficient could be increased to $+ 0.948$ by selecting only those apples scored extremely different in sweetness (averaging 3 or 6 on a 10-point scale). Using this selective method with ΔOD

(630–660 nm.), the correlation coefficient was +0.760 and with ΔOD (700–740 nm.), –0.791.

Based on its relationship to sweetness, ΔOD (580–640 nm.) was selected for tests with ΔOD (700–740 nm.) comparing the effectiveness of the two pairs of wavelengths in sorting apples for quality.

1966 Test

Relationship Between Harvest Date and Light Transmission Category

For both ΔOD (580–640 nm.) and ΔOD (700–740 nm.), the proportion of the total apples in a harvest sorted into each category changed from week to week during the 30-day harvest period. Harvests 1 and 2 yielded many apples with low ΔOD (580–640 nm.) values and high ΔOD (700–740 nm.) values (high chlorophyll). In contrast, a large proportion of the apples from harvests 3 and 4 had high ΔOD (580–640 nm.) values and low ΔOD (700–740 nm.) values (low chlorophyll) (figs. 3 and 4).

If either measurement (ΔOD) is closely related to eating quality, the relationship between optical density difference value and harvest date could be used to decide when to harvest for the greatest yield of high-quality apples.

Difference Meter Values (ΔOD 's) After Storage at 32° F. for 6 Months

Immediately after sorting at harvest by either ΔOD (580–640 nm.) or ΔOD (700–740 nm.), apples were equally distributed among the categories before being placed into storage (figs. 5 and 6). After 6 months' storage, ΔOD (580–640 nm.) values for some apples decreased while others increased, resulting in a wider spread of values (fig. 5). Relationships between ΔOD values measured after storage and eating quality and between physiological changes during storage and changes in ΔOD 's were not determined.

For ΔOD (700–740 nm.) values, a striking shift from positive to negative values occurred during storage (fig. 6). Although a slight decrease in ΔOD (700–740 nm.) values might be expected as chlorophyll content decreases during storage, this shift from positive to negative cannot be explained.

Laboratory and Taste Panel Tests

ΔOD (580–640 nm.).—Apples sorted by ΔOD (580–640 nm.) were not different in firmness at harvest, as shown by Magness-Taylor results and panel texture scores (all categories rated "crisp"). Despite their similar textures, these apples were different in soluble solids, acidity, and other taste panel quality factors. At harvest, apples with higher ΔOD (580–640 nm.) values (categories 4 and 5) were sweeter, less tart, more flavorful, and higher in overall quality than apples with lower values (categories 1, 2, and 3).

After 6 months' storage at 32° F., apples in ΔOD (580–640 nm.) categories 1, 2, and 3 were firmer than those in category 4 (rated "slightly mealy"). The taste panel scored apples in category 5 as sweeter, less tart, and higher in overall quality than apples in category 1, although the two categories were not different in texture (tables 1 and 2).

Apples in ΔOD (580–640 nm.) category 3 contained the most total chlorophyll at harvest. However, the variability among samples for each category was so great that differences between means were not significant, both at harvest and after storage (fig. 7).

ΔOD (700–740 nm.).—Chlorophyll content and ΔOD (700–740 nm.) values showed the following relationship: higher ΔOD (700–740 nm.) value = higher chlorophyll content. After 6 months' storage, apples in category 4 still contained five times as much chlorophyll as apples in category 1 (figs. 7 and 8).

At harvest, apples sorted by ΔOD (700–740 nm.) were different in Magness-Taylor firmness and taste panel texture, ranging from less than crisp to more than crisp. Apples in category 1 (low chlorophyll) were less firm than those in the other categories. These low-chlorophyll apples were sweeter, less tart, more flavorful, and higher in overall quality than apples in the high-chlorophyll category (category 4) (tables 1 and 2).

After 6 months at 32° F., firmness differences between categories were larger than at harvest, ranging from slightly mealy to crisp. Firmer apples had higher ΔOD (700–740 nm.) values

(Text continued on p. 13.)

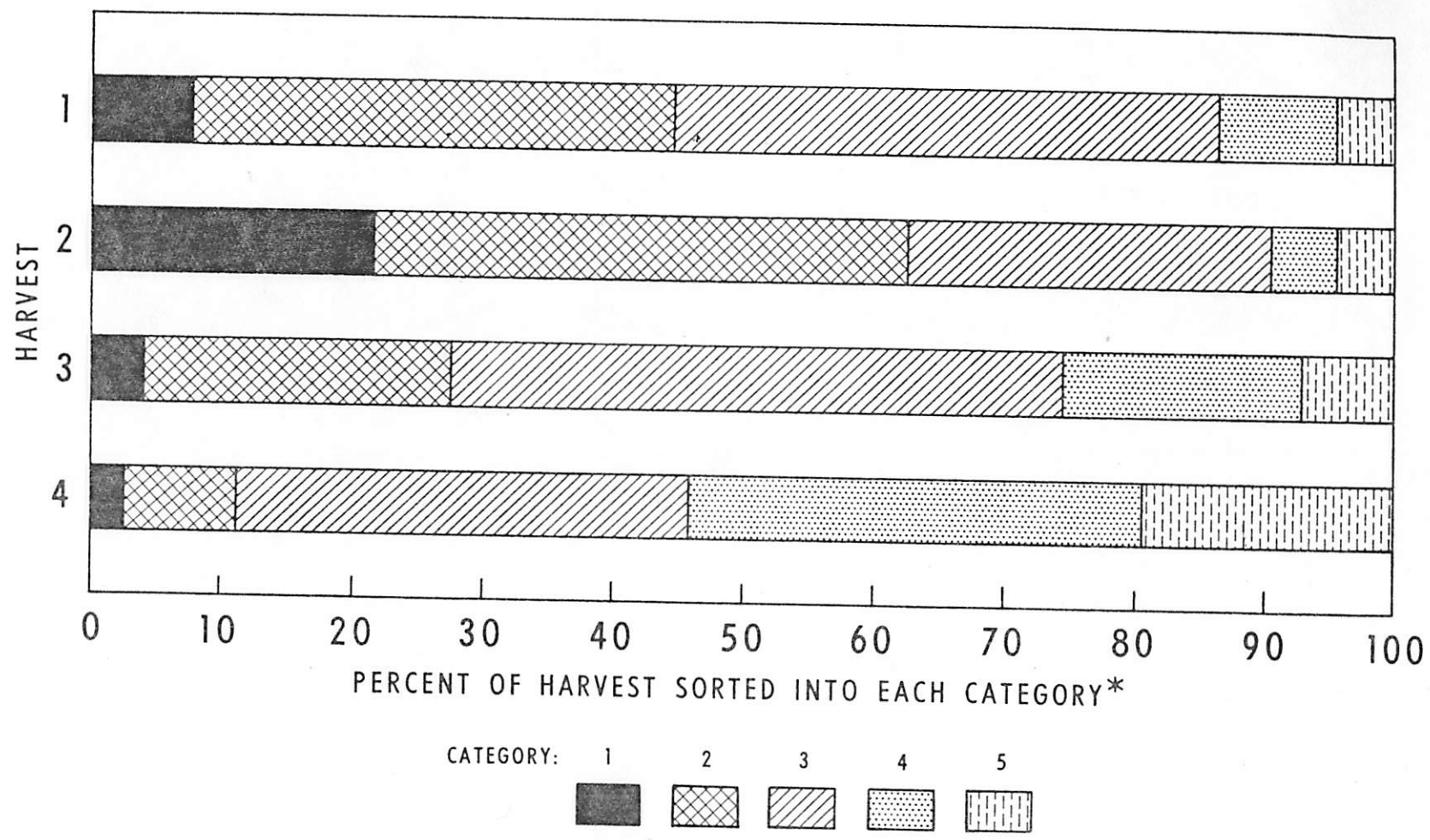

*10 BUSHEL PER HARVEST.
 FIGURE 3.—Relationship between ΔOD (580–640 nm.) category and harvest date, 1966.

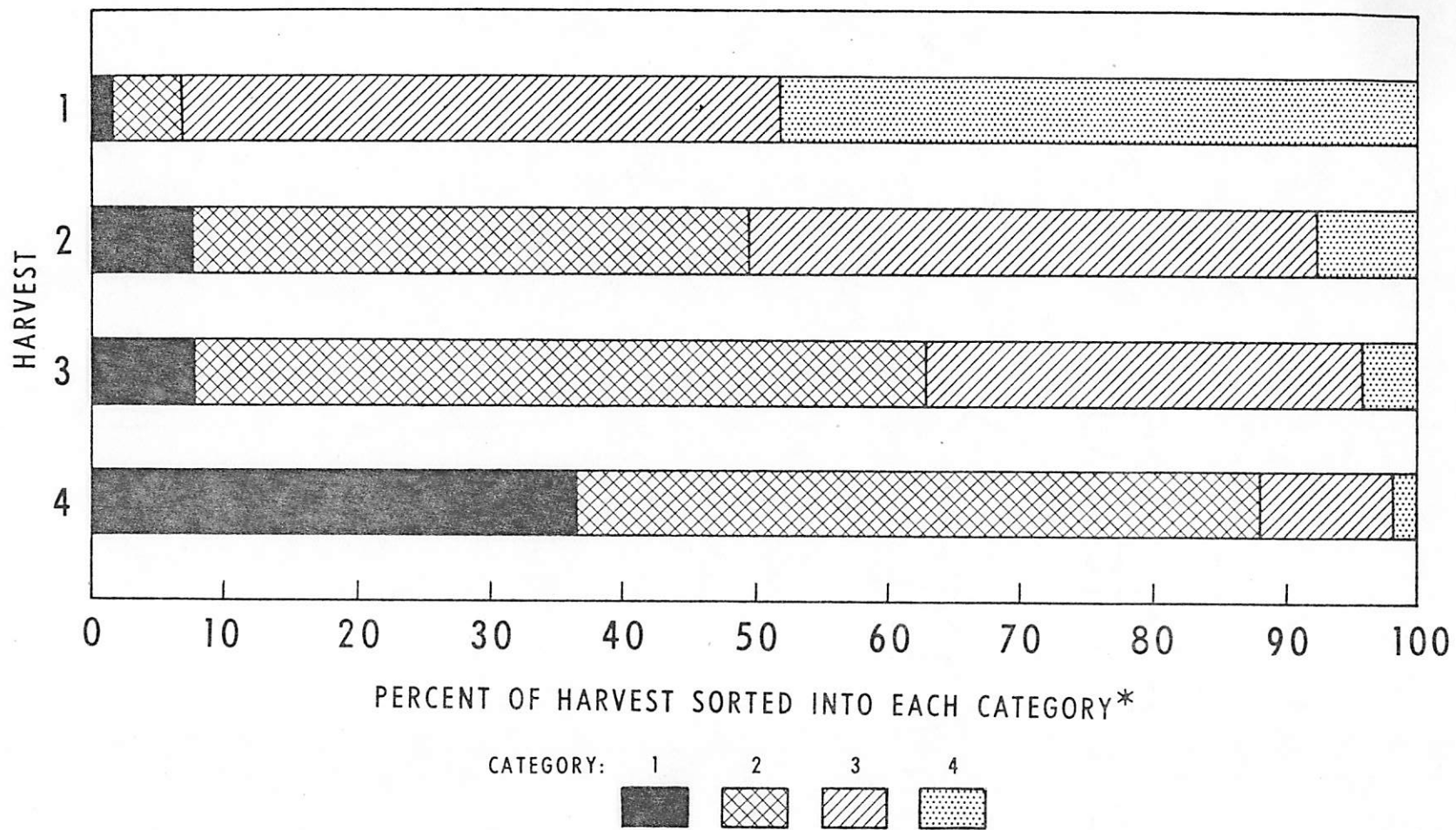

*10 BUSHELS PER HARVEST.

FIGURE 4.—Relationship between ΔOD (700–740 nm.) category and harvest date, 1966.

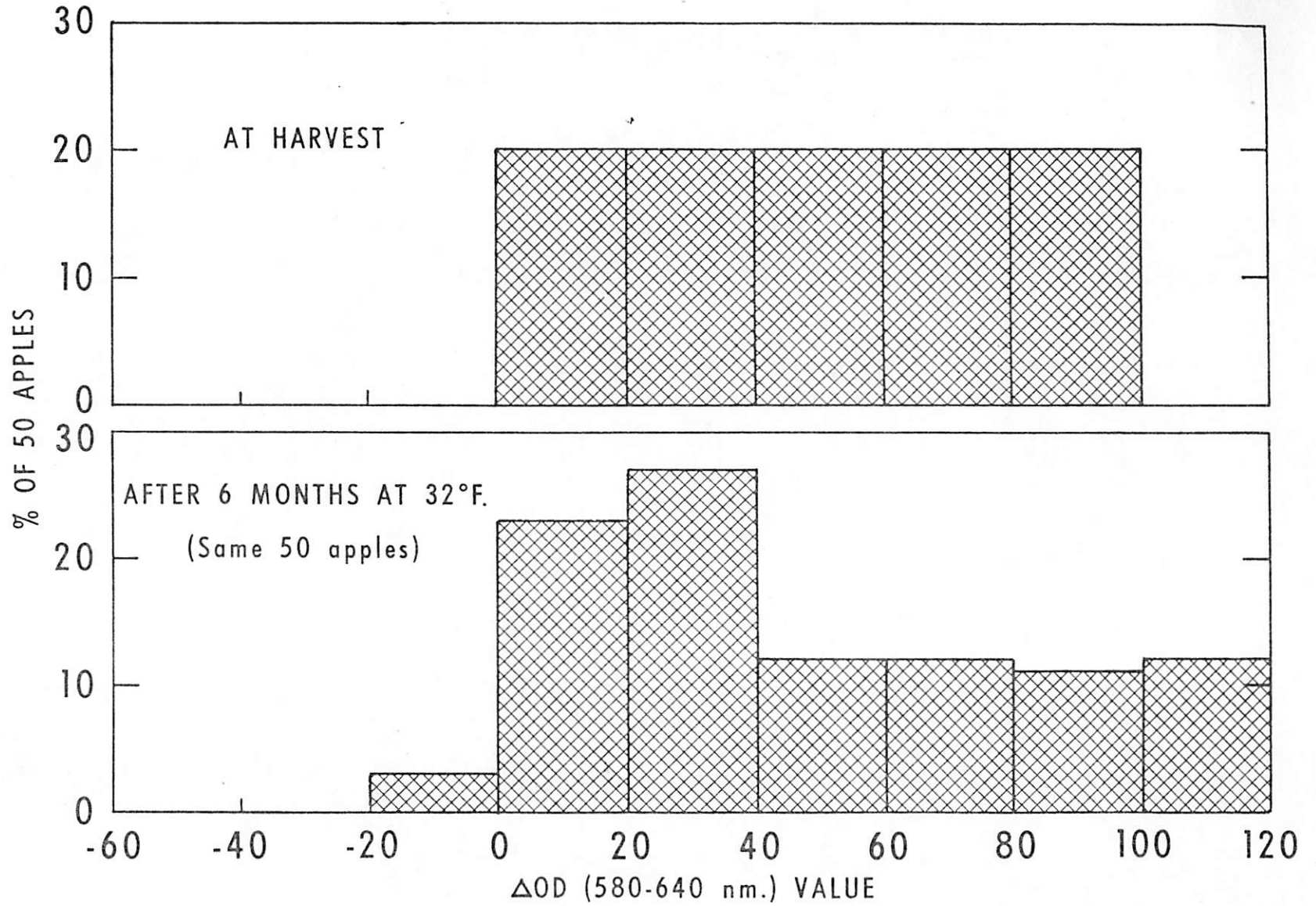

FIGURE 5.—Distribution of $\Delta OD(580-640 \text{ nm.})$ values before and after 6 months' storage at 32° F., 1966.

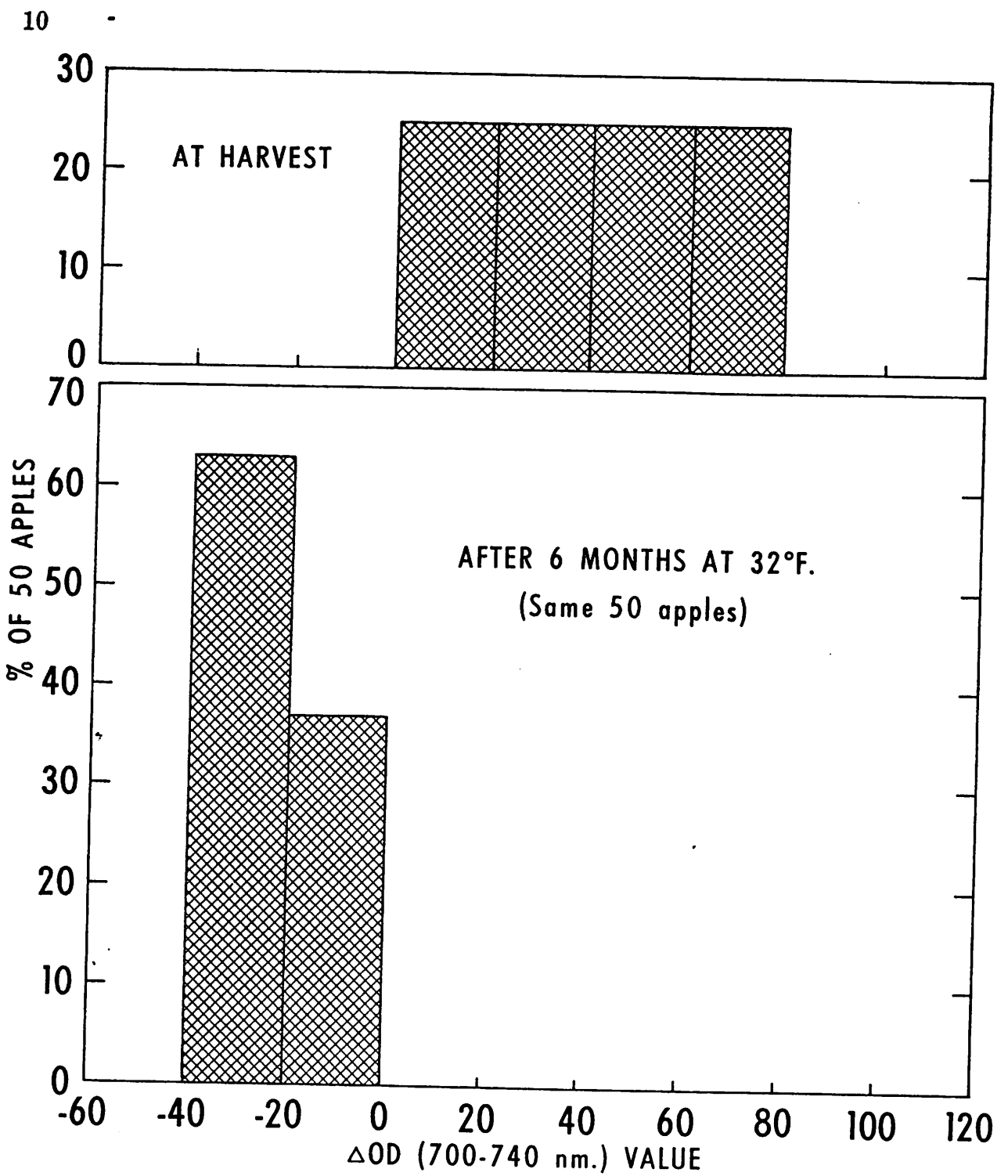
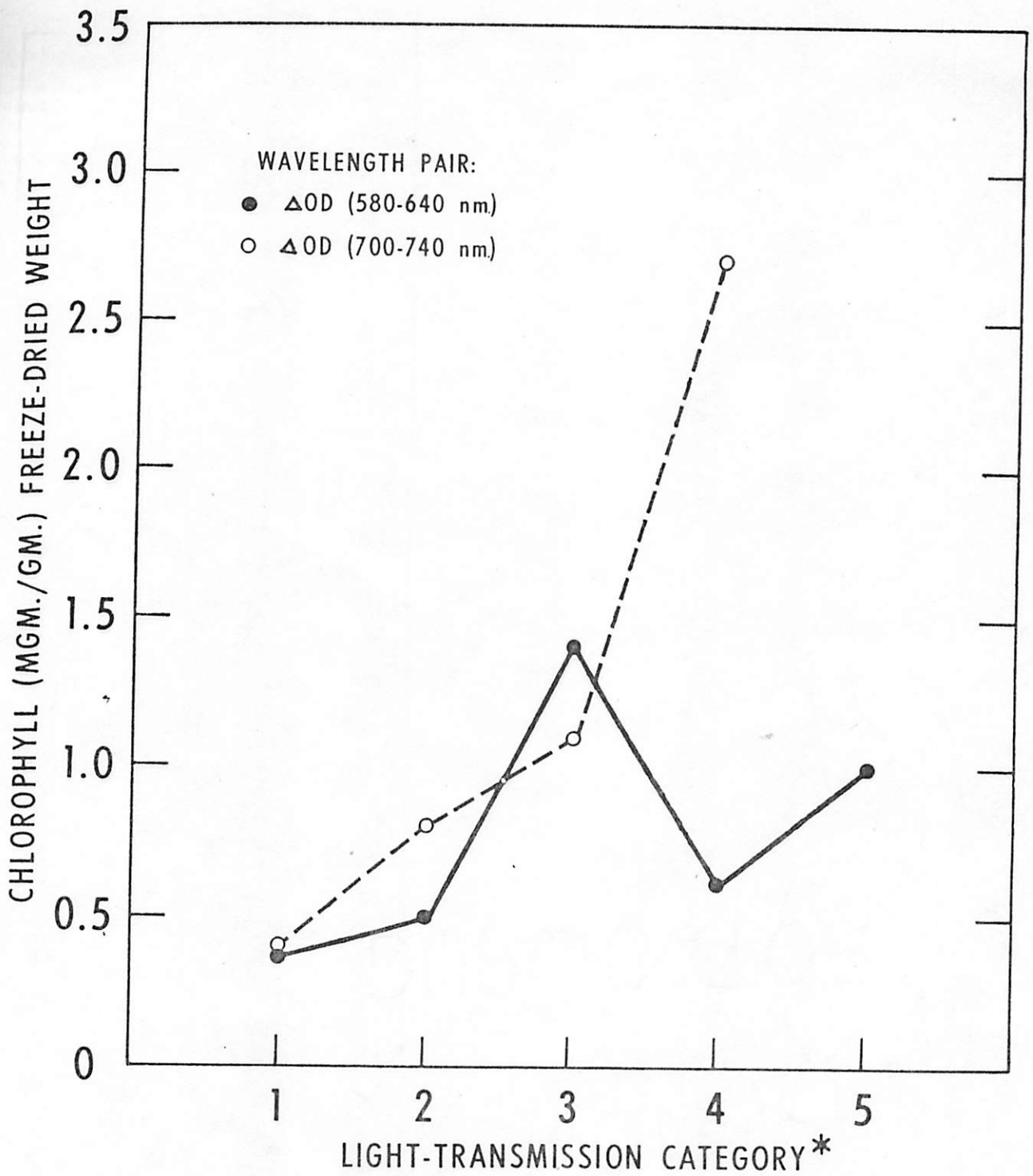
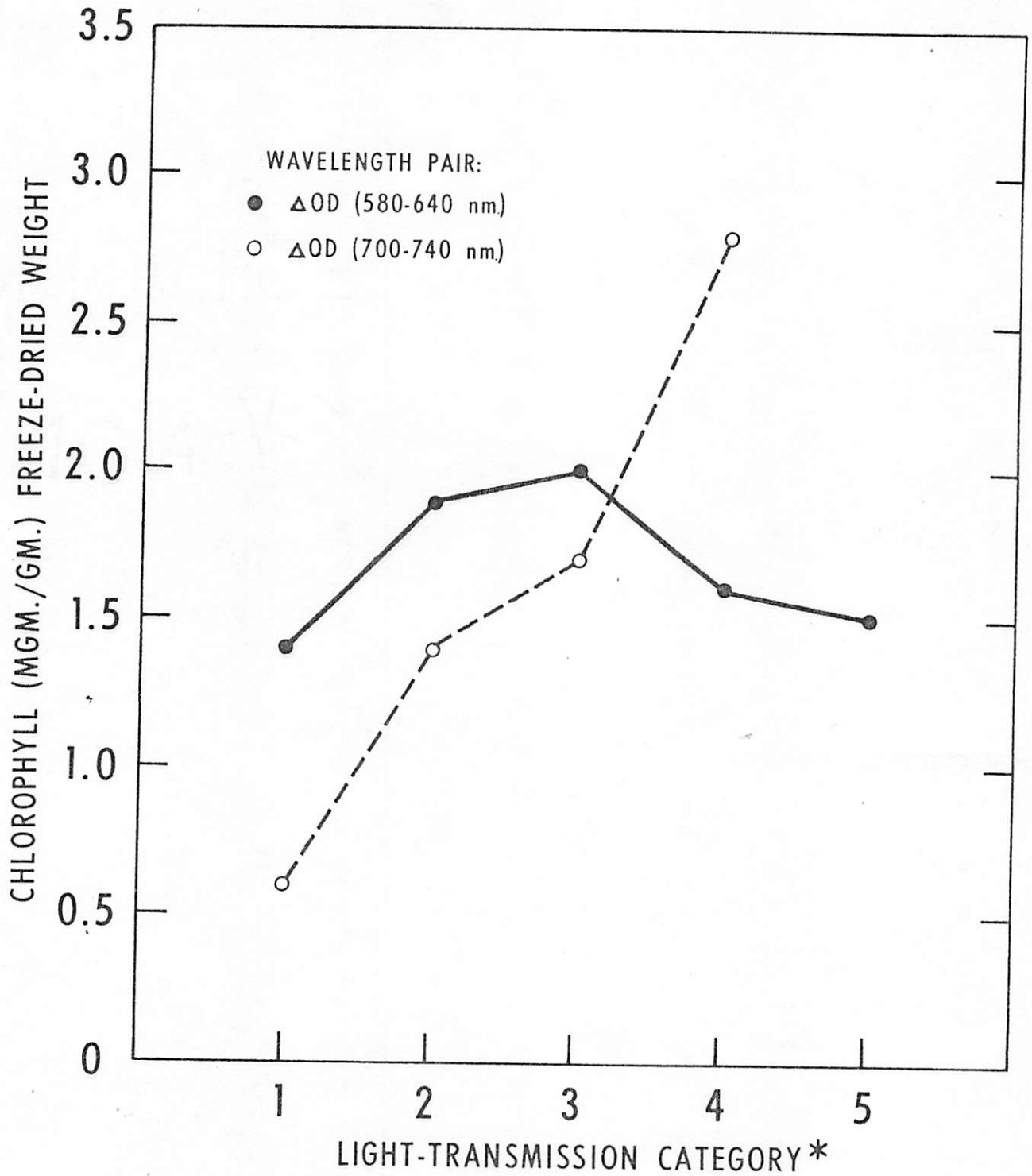

FIGURE 6.—Distribution of $\Delta OD (700-740 \text{ nm.})$ values before and after 6 months' storage at 32° F., 1966.



*EACH POINT THE MEAN OF 30 APPLES
(3 SAMPLES OF 10 APPLES EACH).

FIGURE 7.—Chlorophyll content at harvest, 1966.



*EACH POINT THE MEAN OF 40 APPLES
(4 SAMPLES OF 10 APPLES EACH).

FIGURE 8.—Chlorophyll content after 6 months at 32° F., 1966.

(higher chlorophyll). Yeatman and Norris (8) reported that low-chlorophyll apples were slightly firmer than those with high chlorophyll, but they presented no statistical analyses.

The correlation coefficient for panel texture scores versus Magness-Taylor firmness after storage was $r = +0.85$. Although panelists showed no overall preference for any category after storage, apples in $\Delta OD(700-740 \text{ nm.})$ category 1 (low chlorophyll) were still rated as sweeter, less tart, and more flavorful than those in category 4 (high chlorophyll) (table 2).

Neither $\Delta OD(580-640 \text{ nm.})$ nor $\Delta OD(700-740 \text{ nm.})$ categories were significantly different in juiciness.

1967 Test

Relationship Between $\Delta OD(580-640 \text{ nm.})$ and $\Delta OD(700-740 \text{ nm.})$

$\Delta OD(580-640 \text{ nm.})$ and $\Delta OD(700-740 \text{ nm.})$ values for the same apples were compared to detect any relationship between the two wave-

length pairs. For the 480 apples sorted by $\Delta OD(700-740 \text{ nm.})$, the correlation coefficient between $\Delta OD(580-640 \text{ nm.})$ and $\Delta OD(700-740 \text{ nm.})$ was $r = -0.80$. A plot of the data showed that the negative relationship occurred across the three categories, not within a category. Using only category numbers (1, 2, or 3) in the calculation produced a correlation coefficient of $r = -0.77$. Because the pigment measured by $\Delta OD(580-640 \text{ nm.})$ is not known at this time, explanation of the relationship between this wavelength pair and $\Delta OD(700-740 \text{ nm.})$ is difficult.

Difference Meter Values (ΔOD 's) After Storage

Average difference meter values for $\Delta OD(580-640 \text{ nm.})$ categories increased after 2 and 4 months' storage at 32° F . The rate of increase was greater for apples in conventional storage than for those in the CA room (fig. 9). Between the 4- and 6-month tests, $\Delta OD(580-640 \text{ nm.})$

TABLE 1.—Laboratory results for Red Delicious apples sorted by $\Delta OD(580-640 \text{ nm.})$ and $\Delta OD(700-740 \text{ nm.})$ at harvest and after 6 months' storage at 32° F ., by category, 1966-67¹

Wavelength pair and category	Firmness (lb.) ²		Soluble solids (%) ³		Titratable acidity (%) ³	
	Harvest	6 months	Harvest	6 months	Harvest	6 months
$\Delta OD(580-640 \text{ nm.})$: ⁴						
1 ⁵	17.4	13.0 c	11.9 e	12.8 bc	0.250a	0.198 c
2.....	17.7a	13.6 b	11.9 e	12.4 cde	0.232 b	0.190 cd
3.....	17.7a	13.7 b	12.2 de	12.5 cd	0.235ab	0.180 d
4.....	17.7a	12.5 d	12.8 bc	12.8 bc	0.227 b	0.152 e
5.....	17.7a	12.5 d	13.4a	13.1ab	0.224 b	0.148 e
$\Delta OD(700-740 \text{ nm.})$: ⁴						
1 ⁵	16.8 c	12.0 g	13.4ab	13.5a	0.219 c	0.144 e
2.....	17.5 b	12.5 f	12.6 cd	12.8 bc	0.226 bc	0.179 d
3.....	18.0a	13.7 e	12.1 de	12.7 cd	0.240ab	0.186 d
4 ⁵	18.2a	14.6 d	11.9 e	12.8 bc	0.248a	0.185 d

¹ For each wavelength pair, within a quality factor, means followed by the same letter are not significantly different (5-percent level).

² Mean of 100 measurements (50 apples).

³ Mean of 5 composite samples (10 apples each).

⁴ Category = 20 units on 100-unit scale of difference meter.

⁵ 1 = low chlorophyll; 4 = high chlorophyll.

TABLE 2.—Taste panel results for Red Delicious apples sorted by $\Delta OD(580-640 \text{ nm.})$ and $\Delta OD(700-740 \text{ nm.})$ at harvest and after 6 months' storage at 32° F., by category, 1966-67¹

Wavelength pair and category	Texture		Sweetness		Tartness		Flavor		Overall reaction	
	Harvest	6 months	Harvest	6 months	Harvest	6 months	Harvest	6 months	Harvest	6 months
$\Delta OD(580-640 \text{ nm.})$: ²										
1-----	5.4a	3.9 bc	3.5 e	3.4 e	3.2a	2.2 bc	3.0 b	3.1 b	4.7 cd	4.5 d
2-----	5.2a	4.0 bc	4.0 cde	3.5 e	3.2a	2.1 bc	3.3 b	3.0 b	5.0 cd	4.7 cd
3-----	5.5a	4.4 b	3.7 de	3.8 cde	3.2a	2.2 bc	3.1 b	3.1 b	4.8 cd	4.8 cd
4-----	5.0a	3.3 d	4.7 b	4.3 bcd	2.5 b	1.7 cd	3.8a	3.4 b	5.6ab	4.8 cd
5-----	5.0a	3.5 cd	5.6a	4.4 bc	2.3 b	1.5 d	4.0a	3.4 b	5.9a	5.2 bc
$\Delta OD(700-740 \text{ nm.})$: ²										
1 ³ -----	4.6 b	3.2 c	5.2a	4.3 b	2.5 bc	1.5 d	4.0a	3.2 b	5.6a	4.6 b
2-----	5.3a	3.6 c	4.0 bc	3.8 bcd	3.1ab	2.2 c	3.2 b	3.3 b	4.9ab	5.0ab
3-----	5.5a	4.3 b	3.6 bcd	3.4 cd	3.2a	2.5 bc	3.0 bc	3.1 bc	4.4 b	4.7 b
4 ³ -----	5.6a	4.8 b	3.4 cd	3.1 d	3.2a	2.7abc	2.9 bc	2.7 c	4.3 b	4.5 b

¹ Mean of 5 replications for 5 judges on a 7-pt. scale, except for flavor, that is mean of 5 judges on a 5-pt. scale. For each wavelength pair, within a quality factor, means followed by the same letter are not significantly different (5-percent level).

² Category = 20 units on 100-unit scale of difference meter.

³ 1 = low chlorophyll; 4 = high chlorophyll.

values for apples in the CA room decreased sharply, while values for apples in conventional storage increased or remained the same. This decrease cannot be explained. Laboratory and taste panel tests showed no significant differences between apples from the two storages.

Average values for $\Delta OD(700-740 \text{ nm.})$ categories in both storages decreased slightly during storage. All except apples in the high-chlorophyll category remained within their original category limits (fig. 10). The change from positive to negative values during storage that was observed in the 1966 test did not occur in 1967.

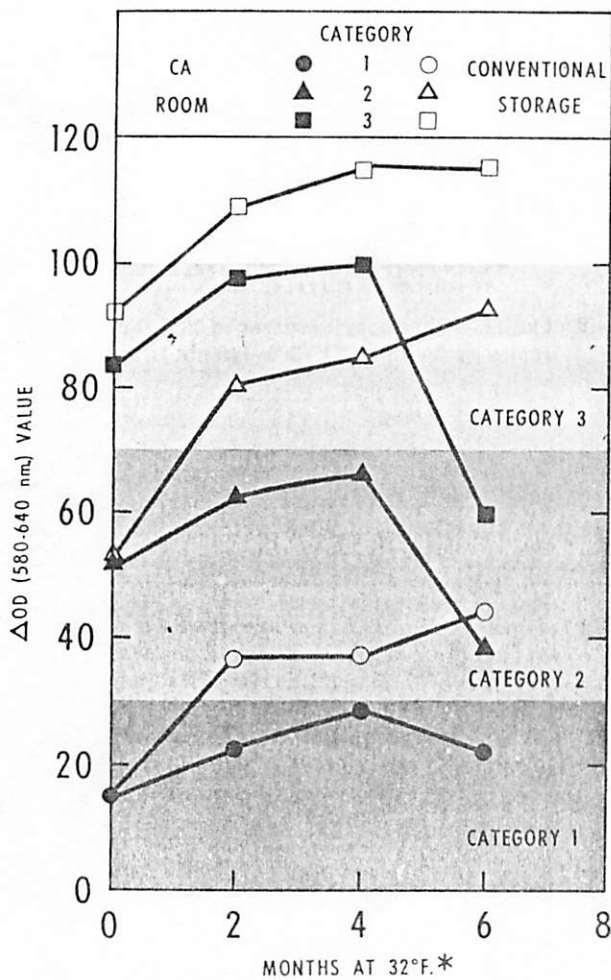

* EACH POINT THE MEAN OF 20 APPLES.

FIGURE 9.—Average $\Delta OD(580-640 \text{ nm.})$ values during storage at 32° F., 1967.

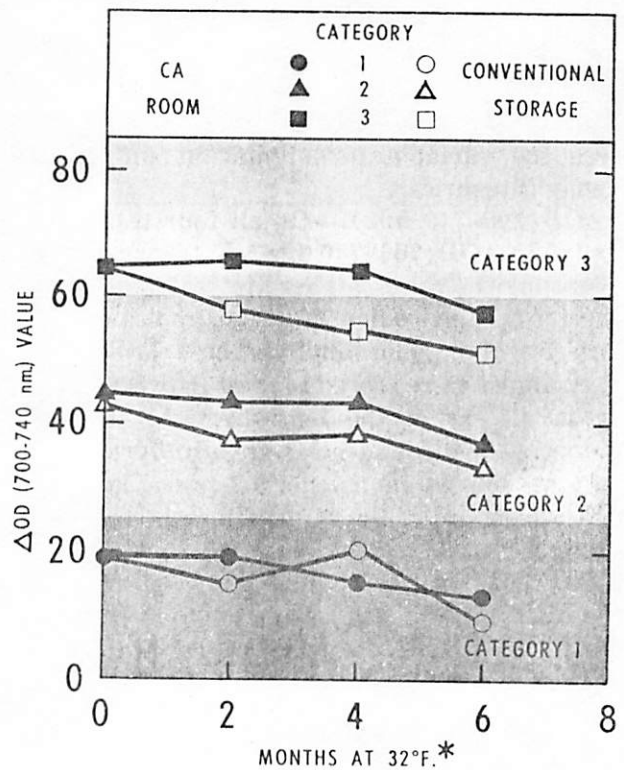

* EACH POINT THE MEAN OF 20 APPLES.

FIGURE 10.—Average $\Delta OD(700-740 \text{ nm.})$ values during storage at 32° F.

Laboratory and Taste Panel Tests

Because analyses or variance showed no significant differences between apples in conventional storage and in the CA room, data are presented as averages of the two storages.

$\Delta OD(580-640 \text{ nm.})$.—At harvest, apples sorted by $\Delta OD(580-640 \text{ nm.})$ were not different in any of the quality factors tested. Differences among categories were found for some quality factors after 2, 4, or 6 months' storage. For example, after 4 months' storage, apples in category 3 were sweeter, lower in acid, and more flavorful than apples in category 1 (tables 3 and 4). Differences among categories were smaller and more variable than those found in the 1966 test. Firmness differences did not develop during storage as they had in 1966.

Apples in category 1 contained more chlorophyll than apples in categories 2 and 3 (fig. 11). These chlorophyll results support the negative

correlation between $\Delta OD(580-640 \text{ nm.})$ and the chlorophyll wavelength pair, $\Delta OD(700-740 \text{ nm.})$. In 1966 apples with midscale values (category 3) were highest in chlorophyll, but data were too variable for significant differences among categories.

$\Delta OD(700-740 \text{ nm.})$.—On all four test dates, apples in $\Delta OD(700-740 \text{ nm.})$ category 1 (low chlorophyll) were higher in soluble solids, sweeter, and more flavorful than apples in category 3 (high chlorophyll). These low-chlorophyll apples were scored highest in overall quality in all except the 2-month test. Although taste panelists found no tartness differences at harvest, apples in category 1 were less tart than those in category 3 after 2, 4, and 6 months' storage (tables 3 and 5).

The positive relationship between firmness and $\Delta OD(700-740 \text{ nm.})$ value found in 1966 was not found in 1967. Magness-Taylor firmness at harvest showed category 1 (low chlorophyll) firmer than category 3 (high chlorophyll), while the taste panel scored category 3 firmer than category 1 after 2 months' storage. For quality factors other than texture, $\Delta OD(700-740 \text{ nm.})$ value at harvest seems a good indicator of after-storage quality.

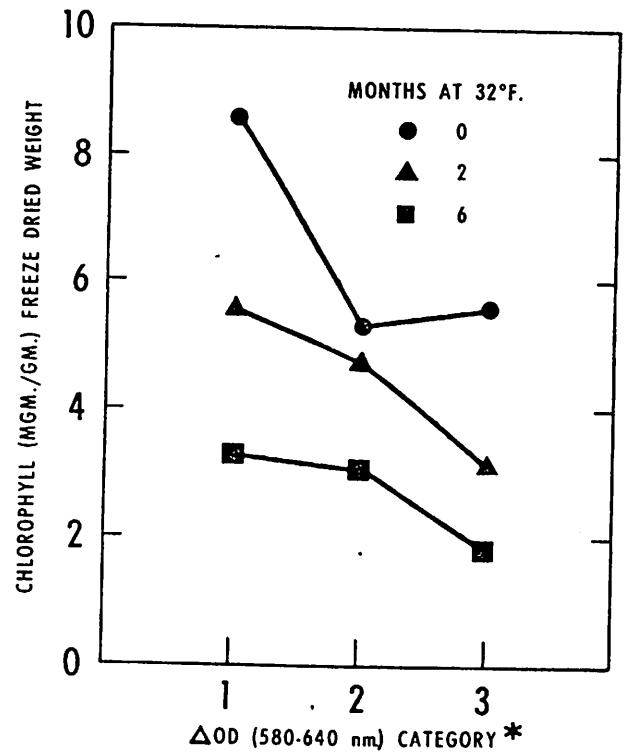

* EACH POINT THE MEAN OF 20 APPLES
(2 SAMPLES OF 10 APPLES EACH).

FIGURE 11.—Chlorophyll content of Red Delicious apples sorted by $\Delta OD(580-640 \text{ nm.})$, 1967.

TABLE 3.—Laboratory results for Red Delicious apples sorted by $\Delta OD(580-640 \text{ nm.})$ and $\Delta OD(700-740 \text{ nm.})$ at harvest and after specified time in storage by category, 1967-1968¹

Wavelength pair, quality factor, and category	At harvest	Months in storage		
		2	4	6
$\Delta OD(580-640 \text{ nm.})$: ²				
Firmness (lb.):				
1.....	17.0a	15.8 b	14.2 de	13.4 f
2.....	17.0a	15.4 bc	14.3 de	13.3 f
3.....	17.4a	15.9 b	14.8 cd	13.7 ef
Soluble solids (%):				
1.....	11.8 e	12.2 cde	12.1 de	13.0abc
2.....	12.1 de	12.7abcd	12.8abcd	13.1ab
3.....	12.4 bcde	12.7abcd	13.1ab	13.4a
Titratable acidity (%):				
1.....	.275a	.256abc	.245 cd	.221 def
2.....	.265abc	.255abc	.224 de	.200 ef
3.....	.273ab	.249 bc	.217 ef	.198 f
$\Delta OD(700-740 \text{ nm.})$: ³				
Firmness (lb.): ⁴				
1.....	17.6a	16.1 bc	14.1 de	13.6 ef
2.....	17.3a	15.8 bc	13.9 de	13.1 f
3.....	16.3 b	15.5 c	14.3 d	13.2 f
Soluble solids: ⁴				
1.....	12.2 cdef	12.7 bc	12.9 b	13.5a
2.....	11.7 f	12.1 cdef	12.4 bcde	13.0 bcd
3.....	11.0 g	11.9 def	11.8 ef	12.5 d
Titratable acidity (%): ⁴				
1.....	.271a	.260a	.236 bc	.208 d
2.....	.264a	.253ab	.226 cd	.208 d
3.....	.256ab	.252ab	.236 bc	.229 c

¹ Mean of 4 composite samples of 10 apples each, except for firmness, that is the mean of 80 measurements (40 apples). For each wavelength pair, within a quality factor, means followed by the same letter are not significantly different.

² Category = 30 units on 100-unit difference meter scale.

³ Category = 25 units on 100-unit difference meter scale.

⁴ 1 = low chlorophyll; 3 = high chlorophyll.

TABLE 4.—Taste panel results for Red Delicious apples sorted by $\Delta OD(580-640 \text{ nm.})$ at harvest and after specified time in storage, by category, 1967-68¹

Quality factor and category ²	At harvest	Months in storage		
		2	4	6
Texture:				
1.....	5.5ab	5.6a	4.8 bcde	5.0abcd
2.....	5.4abc	4.7 cde	4.3 de	4.2 e
3.....	5.6a	5.2abc	4.4 de	4.2 e
Sweetness:				
1.....	3.6 bc	3.4 c	3.8 bc	3.6 c
2.....	3.8 bc	4.5ab	4.5ab	4.4ab
3.....	3.9abc	4.1abc	4.8a	3.9abc
Tartness:				
1.....	3.2ab	3.5a	3.0abc	3.0abc
2.....	3.2ab	2.7 bc	2.5 c	2.4 c
3.....	2.8 bc	2.9abc	2.5 c	2.4 c
Flavor:				
1.....	3.8ab	3.4ab	3.2 b	3.7ab
2.....	4.0a	4.0a	3.8ab	4.0a
3.....	4.0a	3.6ab	3.9a	3.6ab
Overall reaction:				
1.....	5.6abc	4.4 d	4.8 cd	5.4abc
2.....	5.7ab	5.4abc	5.4abc	5.6abc
3.....	5.9a	4.9 bed	5.6abc	5.2abcd

¹ Mean of 4 replications for 5 judges on a 7-pt. scale, except for flavor, that is mean of 5 judges on a 5-pt. scale. Within a quality factor, means followed by the same letter are not significantly different.

² Category = 30 units on 100-unit scale of difference meter.

TABLE 5.—Taste panel results for Red Delicious apples sorted by $\Delta OD(700-740 \text{ nm.})$ at harvest and after specified time in storage, by category, 1967-68¹

Quality factor and category ²	At harvest	Months in storage		
		2	4	6
Texture:				
1 ³	5.4ab	4.8 bed	4.5 cd	4.8 bed
2.....	5.2abc	5.2abc	4.2 d	4.2 d
3 ³	5.1abc	5.6a	4.9abcd	4.9abcd
Sweetness:				
1.....	3.6 bed	4.4ab	4.4ab	4.6a
2.....	3.2 de	4.0abcd	4.2abc	4.4ab
3.....	2.7 e	3.4 cde	3.4 cde	3.2 de
Tartness:				
1.....	3.3abc	2.6 de	2.8 cde	2.4 e
2.....	3.1abcd	3.0 bed	2.6 de	2.6 de
3.....	3.7a	3.6ab	3.3abc	3.0 bed
Flavor:				
1.....	3.8ab	3.8ab	4.0a	4.1a
2.....	3.6abc	3.8ab	3.6abc	3.8ab
3.....	3.2 cd	3.0 d	3.2 cd	3.3 bed
Overall reaction:				
1.....	5.5ab	4.8 bed	5.6ab	6.0a
2.....	5.4ab	5.0 bed	5.2abc	5.6ab
3.....	4.6 cd	4.2 d	4.6 cd	4.8 bed

¹ Mean of 4 replications for 5 judges on a 7-pt. scale, except for flavor, that is mean of 5 judges on a 5-pt. scale. Within a quality factor, means followed by the same letter are not significantly different.

² Category = 25 units on 100-unit scale of difference meter.

³ 1 = low chlorophyll; 3 = high chlorophyll.

CONCLUSIONS AND RECOMMENDATIONS

Red Delicious apples can be sorted for quality by a light-transmission measurement of internal pigmentation. During the 3-year test, $\Delta OD(700-740 \text{ nm.})$, the chlorophyll wavelength pair, was a more reliable indicator of internal quality than $\Delta OD(580-640 \text{ nm.})$.

The $\Delta OD(700-740 \text{ nm.})$ value of an apple at harvest is related to its quality after 6 months' storage at 32°F . However, some growers may prefer bulk bin storage followed by sorting and packing immediately before shipment. More information is needed on the relation of after-storage ΔOD values to after-storage eating quality.

Because of variable conditions in the CA room, no conclusions about the effects of CA versus conventional storage on apples sorted by light transmission can be made from this study.

Many laboratory and taste panel quality factors were measured during the tests because "apple quality" can be defined in many ways. Few of the apples were actually "unacceptable" to the taste panel. Light transmission sorting would enable the grower to sort apples into groups that are different in specific quality factors. High-quality apples could be sold soon after harvest at a premium price, while others could be stored.

The market for which the apples are intended would determine which group would be labeled high quality. Our laboratory panel preferred apples that were less firm, sweeter, and less tart. However, consumer tests on a larger scale are needed before deciding on quality labels for specific groups of consumers.

In a survey on the use of selected fresh and processed fruits (4), homemakers were asked

what a store manager could do to sell more fresh fruits. Almost 50 percent responded, "Display high-quality fruit." One in four homemakers who had bought fresh fruit during the previous 12 months was disappointed with her purchases. The market for high-quality apples exists, awaiting a reliable automated measurement of quality.

Determining the best harvest date may be another valuable application for light-transmission sorting. Although the data on harvest date versus optical density difference represent only one year (1966) for one orchard of Red Delicious, the shift in the distribution of ΔOD values over a 4-week harvest period was striking. More research is needed on the number of apples required for a reliable sample. From the $\Delta OD(700-740 \text{ nm.})$ values of a sample, a grower might decide to harvest when a large proportion of his apples fall into a defined high-quality group. As mechanical harvesting becomes more universal, the grower could schedule his equipment in various parts of his orchards to yield the greatest return for his investment.

To be a valuable and practical tool, light-transmission measurements should be reliable from year to year for many varieties in widespread locations. Light-transmission sorting is still in its infancy as a quality measurement. More research is needed on the variation that can be expected because of season, orchard, variety, and harvest date. Research of this type has been conducted for many years on factors such as apple soluble solids and flesh firmness. Reliable standard settings, zero values, and other instrumental guidelines are necessary for a numerical ΔOD value to have practical meaning.

LITERATURE CITED

- (1) ANDERSON, R. E.
1967. EXPERIMENTAL STORAGE OF EASTERN-GROWN DELICIOUS APPLES IN VARIOUS CONTROLLED ATMOSPHERES. *Amer. Soc. Hort. Sci. Proc.* 91: 810-820.
- (2) BIRTH, G. S., and NORRIS, K. H.
1965. THE DIFFERENCE METER FOR MEASURING INTERIOR QUALITY OF FOODS AND PIGMENTS IN BIOLOGICAL TISSUES. U.S. Dept. Agr. Tech. Bul. 1341, 20 pp.
- (3) ——— and OLSEN, K. L.
1964. NONDESTRUCTIVE DETECTION OF WATER CORE IN DELICIOUS APPLES. *Amer. Soc. Hort. Sci. Proc.* 85: 74-84.
- (4) CLAYTON, L. Y.
1966. HOMEMAKERS' USE OF AND OPINIONS ABOUT SELECTED FRUITS AND FRUIT PRODUCTS. U.S. Dept. Agr., Mktg. Res. Rpt. 765, 78 pp.
- (5) NORRIS, K. H.
1958. MEASURING LIGHT TRANSMITTANCE PROPERTIES OF AGRICULTURAL COMMODITIES. *Agr. Engin.* 39: 640-651.
- (6) OLSEN, K. L., SCHOMER, H. A., and BARTRAM, R. D.
1967. SEGREGATION OF GOLDEN DELICIOUS APPLES FOR QUALITY BY LIGHT TRANSMISSION. *Amer. Soc. Hort. Sci. Proc.* 91: 821-828.
- (7) SIDWELL, A. P., BIRTH, G. S., ERNEST, J. V., and GOLUMBIC, CALVIN.
1961. THE USE OF LIGHT TRANSMITTANCE TECHNIQUES TO ESTIMATE THE CHLOROPHYLL CONTENT AND STAGE OF MATURATION OF ELBERTA PEACHES. *Food Technol.* 15: 75-78.
- (8) YEATMAN, J. N., and NORRIS, K. H.
1965. EVALUATING INTERNAL QUALITY OF APPLES WITH NEW AUTOMATIC FRUIT SORTER. *Food Technol.* 19: 123-125.